



ETA-Danmark A/S
Göteborg Plads 1
DK-2150 Nordhavn
Tel. +45 72 24 59 00
Fax +45 72 24 59 04
Internet www.etadanmark.dk

Authorised and notified according
to Article 29 of the Regulation (EU)
No 305/2011 of the European
Parliament and of the Council of 9
March 2011

MEMBER OF EOTA



European Technical Assessment ETA-10/0009 of 2015-01-26

I General Part

Technical Assessment Body issuing the ETA and designated according to Article 29 of the Regulation (EU) No 305/2011: ETA-Danmark A/S

Trade name of the construction product:

GH Concealed beam hangers type 0-2, I-2, II-2, III-2, IV-2, 0-4, I-4, II-4, III-4 and IV-4

Product family to which the above construction product belongs:

Three-dimensional nailing plate (concealed beam hangers)

Manufacturer:

GH-Baubeschläge GmbH
Austraße 34
D-73235 Weilheim/Teck
Tel. +49 7023 743323 0
Fax +49 7023 743323 90
Internet www.holzverbinder.de

Manufacturing plant:

Werk 1, Werk 2

This European Technical Assessment contains:

11 pages including 3 annexes which form an integral part of the document

This European Technical Assessment is issued in accordance with Regulation (EU) No 305/2011, on the basis of:

Guideline for European Technical Approval (ETAG) No. 015 Three Dimensional Nailing Plates, April 2013, used as European Assessment Document (EAD).

This version replaces:

The previous ETA with the same number issued on 2010-01-26 and expiry on 2015-01-26

Translations of this European Technical Assessment in other languages shall fully correspond to the original issued document and should be identified as such.

Communication of this European Technical Assessment, including transmission by electronic means, shall be in full (excepted the confidential Annex(es) referred to above). However, partial reproduction may be made, with the written consent of the issuing Technical Assessment Body. Any partial reproduction has to be identified as such.

II SPECIFIC PART OF THE EUROPEAN TECHNICAL ASSESSMENT

1 Technical description of product and intended use

Technical description of the product

GH concealed beam hangers are one-piece, face-fixed concealed beam hangers to be used in timber to timber connections.

The concealed beam hangers are made from pre-galvanized steel grade S250 GD+Z275 to EN 10346:2009 or DX51D + Z (min Z275) according to EN 10327:2004 with a minimum R_e of 250 MPa, a maximum tensile strength R_m of 360 MPa and a minimum ultimate strain A_{80} of 19 % with tolerances according to EN 10143:1993. Dimensions, hole positions, steel type and typical installations are shown in Annex A.

2 Specification of the intended use in accordance with the applicable EAD

The concealed beam hangers are intended for use in making end-grain to side-grain connections in load bearing timber structures, as a connection between a wood based joist and a solid timber or wood based header or column, where requirements for mechanical resistance and stability and safety in use in the sense of the Basic Works Requirements 1 and 4 of Regulation (EU) 305/2011 shall be fulfilled.

The concealed beam hangers can be installed as connections between wood based members such as:

- Structural solid timber classified to C14-C40 according to EN 338 / EN 14081,
- Glulam classified to GL24-GL36 according to EN 1194 / EN 14080,
- LVL according to EN 14374,
- Parallam PSL,
- Intrallam LSL,
- Duo- and Triobalken,
- Layered wood plates,
- Plywood according to EN 636.

However, the calculation methods are only allowed for a characteristic wood density of up to 460 kg/m³. Even though the wood based material may have a larger density, this must not be used in the formulas for the load-carrying capacities of the fasteners.

Annex B states the formulas for the load-carrying capacities of the connections with concealed beam

hangers. The design of the connections shall be in accordance with Eurocode 5 or a similar national Timber Code.

It is assumed that the forces acting on the concealed beam hanger connection are F_{up} or F_{down} perpendicular to the header axis. The forces F_{up} and F_{down} shall act in the symmetry plane of the concealed beam hanger. It is assumed that the forces are acting with an eccentricity e with regard to side grain surface of the header.

It is assumed that the header beam or column is prevented from rotating. If the header beam or column only has installed a concealed beam hanger on one side the eccentricity moment

$$M_v = F_d \cdot (B_H / 2 + 40\text{mm})$$

shall be considered. The same applies when the header or column has concealed beam hanger connections on both sides, but with vertical forces which differ more than 20%.

The concealed beam hangers are intended for use for connections subject to static or quasi static loading.

The zinc-coated hangers are for use in timber structures subject to the dry, internal conditions defined by the service classes 1 and 2 of EN 1995-1-1:2004, (Eurocode 5).

The scope of the hangers regarding resistance to corrosion shall be defined according to national provisions that apply at the installation site considering environmental conditions.

The provisions made in this European Technical Assessment are based on an assumed intended working life of the connectors of 50 years.

The indications given on the working life cannot be interpreted as a guarantee given by the producer or Assessment Body, but are to be regarded only as a means for choosing the right products in relation to the expected economically reasonable working life of the works.

3 Performance of the product and references to the methods used for its assessment

Characteristic	Assessment of characteristic
3.1 Mechanical resistance and stability*) (BWR1)	
Characteristic load-carrying capacity	See Annex B
Stiffness	No performance determined
Ductility in cyclic testing	No performance determined
3.2 Safety in case of fire (BWR2)	
Reaction to fire	The concealed beam hangers are made from steel classified as Euroclass A1 in accordance with EN 1350-1 and EC decision 96/603/EC, amended by EC Decision 2000/605/EC
3.3 Hygiene, health and the environment (BWR3)	
Influence on air quality	The product does not contain/release dangerous substances specified in TR 034, dated March 2012 0**)
3.7 Sustainable use of natural resources (BWR7)	
	No Performance Determined
3.8 General aspects related to the performance of the product	
	The concealed beam hangers have been assessed as having satisfactory durability and serviceability when used in timber structures using the timber species described in Eurocode 5 and subject to the conditions defined by service class 1 and 2
Identification	See Annex A

*) See additional information in section 3.8 – 3.9.

**) In addition to the specific clauses relating to dangerous substances contained in this European technical Assessment, there may be other requirements applicable to the products falling within its scope (e.g. transposed European legislation and national laws, regulations and administrative provisions). In order to meet the provisions of the Construction Products Regulation, these requirements need also to be complied with, when and where they apply.

3.9 Methods of verification

The characteristic load-carrying capacities are based on the characteristic values of the connectors and the steel plates.

According to EN 1990 (Eurocode – Basis of design) paragraph 6.3.5 the design value of load-carrying capacity can be determined by reducing the characteristic values of the load-carrying capacity with different partial factors.

Therefore, to obtain design values according to the Eurocodes or appropriate national codes of practice, the capacities have to be multiplied with different partial factors for the material properties and – for the connectors mounted in wood – also the coefficient k_{mod} that takes into account the load duration class.

Thus, the characteristic values of the load-carrying capacity are determined also for timber failure $F_{Rk,H}$ (obtaining the embedment strength of connectors subjected to shear or the withdrawal capacity of the most loaded connector, respectively) as well as for steel plate failure $F_{Rk,S}$. The design value of the load-carrying capacity is the smaller value of both load-carrying capacities.

$$F_{Rd} = \min \left\{ \frac{k_{mod} \cdot F_{Rk,H}}{\gamma_{M,H}}, \frac{F_{Rk,S}}{\gamma_{M,S}} \right\}$$

Therefore, for timber failure the load duration class and the service class are included. The different partial factors γ_M for steel or timber, respectively, are also correctly taken into account.

3.10 Mechanical resistance and stability

See annex B for characteristic load-carrying capacities of the concealed beam hangers.

The characteristic capacities of the concealed beam hangers are determined by calculation assisted by testing as described in the EOTA Guideline 015 clause 5.1.2. They should be used for designs in accordance with Eurocode 5 or a similar national Timber Code.

The design models allow the use of fasteners described in the table on page 10 in Annex A:

Threaded nails (ringed shank nails) in accordance to EN 14592

In the formulas in Annex B the capacities for threaded nails calculated from the formulas of Eurocode 5 are

used assuming a thick steel plate when calculating the lateral nail load-carrying-capacity.

The load bearing capacities of the brackets has been determined based on the use of connector nails 4,0 x 40 mm in accordance with the German national approval for the nails.

The characteristic withdrawal capacity of the nails has to be determined by calculation in accordance with EN 1995-1-1: 2004, paragraph 8.3.2 (head pull-through is not relevant):

$$F_{ax,Rk} = f_{ax,k} \times d \times t_{pen}$$

Where:

$f_{ax,k}$	Characteristic value of the withdrawal parameter in N/mm ²
d	Nail diameter in mm
t_{pen}	Penetration depth of the profiles in mm

Based on tests by Versuchsanstalt für Stahl, Holz und Steine, University of Karlsruhe, the characteristic value of the withdrawal resistance for the threaded nails used can be calculated as:

$$f_{ax,k} = 50 \times 10^{-6} \times \sigma_k^2$$

Where:

σ_k	Characteristic density of the timber in kg/m ³
------------	---

The shape of the nail directly under the head shall be in the form of a truncated cone with a diameter under the nail head which exceeds the hole diameter.

No performance has been determined in relation to ductility of a joint under cyclic testing. The contribution to the performance of structures in seismic zones, therefore, has not been assessed.

No performance has been determined in relation to the joint's stiffness properties - to be used for the analysis of the serviceability limit state.

3.11 Aspects related to the performance of the product

2.7.1 Corrosion protection in service class 1 and 2.

In accordance with ETAG 015 the zinc-coated concealed beam hangers have a zinc coating weight of min Z275. The steel employed is S250 GD+Z275 to EN 10346:2009 or DX51D with min Z275 according to EN 10346:2009.

3.12 General aspects related to the fitness for use of the product

Concealed beam hanger connections

The performance given in this ETA are based on the following:

Header – support conditions

- The header beam or column shall be restrained against rotation and be free from wane under the concealed beam hanger.

If the header or column carries joists only on one side the eccentricity moment from the joists $M_{ec} = R_{joist} (b_{header}/2 + 40\text{mm})$ shall be considered at the strength verification of the header or column.

R_{joist} Reaction force from the joists
 b_{header} Width of header or column

- For a header or column with joists from both sides but with different reaction forces a similar consideration applies.

Wood to wood connections

- Concealed beam hangers are fastened to wood-based members by nails or screws.
- There shall be nails or screws in all holes or a partial nailing pattern as prescribed in Annex A-B may be used.
- The characteristic capacity of the concealed beam hanger connection is calculated according to the manufacturer's technical documentation, dated 2009-09-26.
- The concealed beam hanger connection is designed in accordance with Eurocode 5 or an appropriate national code.
- The gap between the end of the joist and the surface, where contact stresses can occur during loading shall be limited. This means that for concealed beam hangers the gap between the header plate and the end of the joist shall be maximum 8 mm.
- The header or column shall have a plane surface against the whole concealed beam hanger.
- The depth of the joist shall be so large that the top (bottom) of the joist is at least $a_{4,t}$ above (below) the upper (lower) dowel in the joist.
- Nails or screws to be used shall have a diameter, which fits the holes of the concealed beam hangers.

4 Attestation and verification of constancy of performance (AVCP)

4.1 AVCP system

According to the decision 97/638/EC of the European Commission¹, as amended, the system(s) of assessment and verification of constancy of performance (see Annex V to Regulation (EU) No 305/2011) is 2+.

5 Technical details necessary for the implementation of the AVCP system, as foreseen in the applicable EAD

Technical details necessary for the implementation of the AVCP system are laid down in the control plan deposited at ETA-Danmark

Issued in Copenhagen on 2015-01-26 by



Thomas Bruun
Managing Director, ETA-Danmark

Annex A Product details and definitions

Concealed beam hanger

Face mount hanger with flanges. 3.0 mm thick pre-galvanized steel S250 GD+Z275 to EN 10346:2009 or DX51D + Z (min Z275) according to EN 10346:2009 with a minimum R_e of 250 MPa, a maximum tensile strength R_m of 360 MPa and a minimum ultimate strain A_{80} of 19 % with tolerances according to EN 10143:1993.

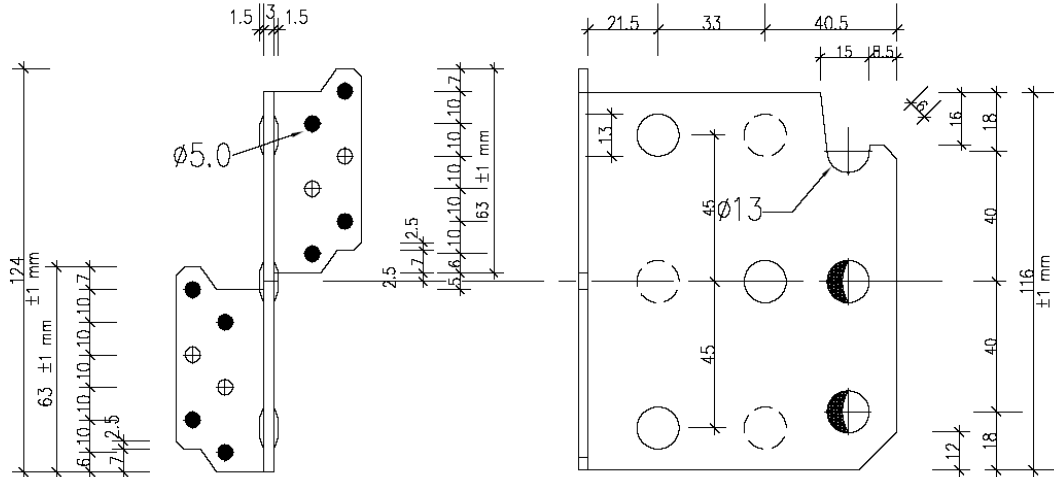

Drawing: concealed beam hanger I-2; ● partial nailing

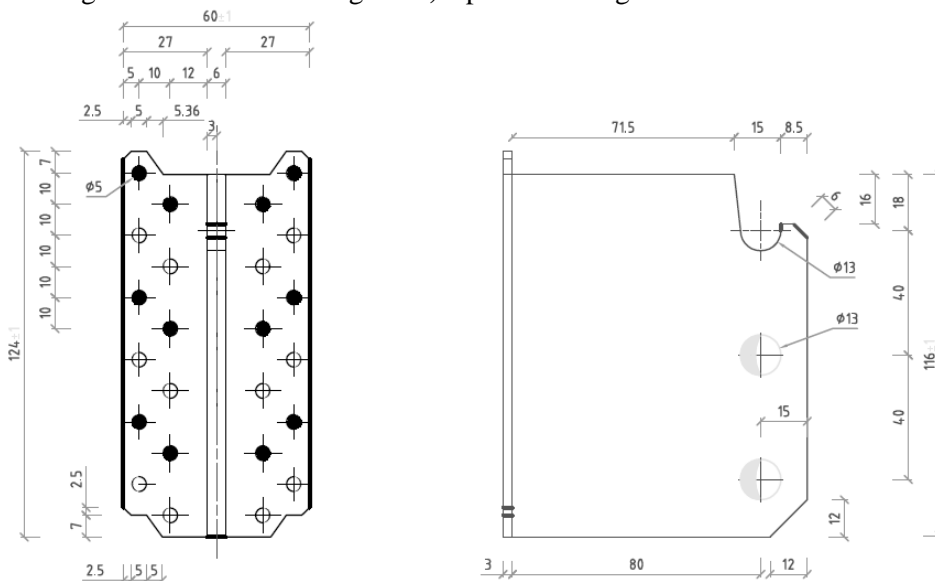

Drawing: concealed beam hanger I-4; ● partial nailing

Beam hanger	N° of nail holes		N° of bolt holes	
	N°	d	N°	d
0-2	8	5	2	13
I-2	12	5	3	13
II-2	16	5	4	13
III-2	20	5	5	13
IV-2	24	5	6	13
0-4	16	5	2	13
I-4	24	5	3	13
II-4	32	5	4	13
III-4	40	5	5	13
IV-4	48	5	6	13

Fastener specification

FASTENER	Length Min – max	Nail type
Nail 4.0 mm	50 – 100 mm	Ringed shank nails according to EN 14592
GH screw 5.0 mm	40 – 70 mm	Self-tapping screws according to EN 14592
GH-Nail 4.0 mm	40 – 100 mm	Ringed shank nails according to ETA-13/0523
GH-Screw 5.0 mm	35 – 70 mm	Self-tapping screws according to ETA-13/0523

In the load-carrying-capacities of the nailed or screwed connection in Annex B the capacities calculated from the formulas of Eurocode 5 are used assuming a thick steel plate when calculating the lateral fastener load-carrying-capacity. The load-carrying-capacities of the hold downs have been determined based on the use of connector nails \varnothing 4,0 mm or screws \varnothing 5,0 mm in accordance with the German national approval for the nails or the screws. The characteristic withdrawal capacity of the nails or screws has to be determined by calculation in accordance with EN 1995-1-1:2008, paragraph 8.3.2 (head pull-through is not relevant):

$$F_{ax,Rk} = f_{1,k} \times d \times t_{pen}$$

Where:

$f_{1,k}$ Characteristic value of the withdrawal parameter in N/mm²

d Nail or screw diameter in mm

t_{pen} Penetration depth of the profiled shank in mm;

(4,0 x 50 mm $t_{pen} \geq 40$ mm; 4,0 x 60 mm $t_{pen} \geq 50$ mm)

Based on tests by Versuchsanstalt für Stahl, Holz und Steine, University of Karlsruhe, the characteristic value of the withdrawal resistance for the threaded nails or screws used can be calculated as:

$$f_{1,k} = 50 \times 10^{-6} \times \rho_k^2 \text{ for nails}$$

$$f_{1,k} = 80 \times 10^{-6} \times \rho_k^2 \text{ for screws}$$

Where:

ρ_k Characteristic density of the timber in kg/m³

The shape of the nail or screw directly under the head shall be in the form of a truncated cone with a diameter under the head which fits or exceeds the hole diameter.

DOWELS diameter	Correspondence hole diameter in steel plate	Dowels type
12.0	Max. 1 mm. larger than the dowel diameter	dowels according to EN 14592

Annex B Load-carrying-capacities

The downward and the upward directed forces are assumed to act in the middle of the joist.

A full nailing pattern, where there are nails or screws in all the holes of the header connection and a partial nailing pattern, where there are only nails or screws in marked holes of the column connection are specified. Dowels are placed in all the dowel holes in the joist.

B.1 Concealed beam hangers fastened with nails and dowels

$$F_{Z,Rd} = \min \left\{ \begin{array}{l} n_{J,ef} \cdot F_{v,J,Rd} \\ \frac{1}{\sqrt{\left(\frac{1}{n_H \cdot F_{v,H,Rd}}\right)^2 + \left(\frac{1}{k_H \cdot F_{ax,H,Rd}}\right)^2}} \end{array} \right. \quad (B.1)$$

$n_{J,ef}$ effective number of dowels in the joist, see Table B.1

n_H total number of nails or screws in the side of the header or column

$F_{v,J,Rd}$ Design lateral load-carrying capacity of a dowel with two shear planes in the joist

$F_{v,H,Rd}$ Design lateral load-carrying capacity of a nail or screw in single shear in the header assuming a thick steel plate

$F_{ax,H,Rd}$ Design axial load-carrying capacity of a nail or screw in the header or column

k_H form factor, see Tables B.1 and B.2

Table B.1: GH concealed beam hangers: Form factors k_H and effective number of dowels $n_{J,ef}$ for full nailing pattern

Beam hanger	n_J	n_H	k_H	$n_{J,ef}$	k_H	$n_{J,ef}$
			Loading DOWN		Loading UP	
0-2	2	8	7,33	0,59	2,27	0,96
I-2	3	12	17,4	1,16	11,0	0,77
II-2	4	16	31,7	1,85	20,1	1,45
III-2	5	20	62,8	2,49	31,7	2,26
IV-2	6	24	91,4	3,33	46,1	3,16
0-4	2	16	8,21	0,86	4,39	0,96
I-4	3	24	19,4	1,57	13,3	1,33
II-4	4	32	31,8	2,61	24,3	2,27
III-4	5	40	45,8	3,80	35,8	3,47
IV-4	6	48	66,6	4,81	52,1	4,47

Table B.1: GH concealed beam hangers: Form factors k_H and effective number of dowels $n_{J,ef}$ for partial nailing pattern

Beam hanger	n_J	n_H	k_H	$n_{J,ef}$	k_H	$n_{J,ef}$
			Loading DOWN		Loading UP	
0-2	2	4	4,31	0,28	0,95	0,96
I-2	3	8	29,9	0,96	10,1	0,65
II-2	4	8	∞	1,39	24,9	1,01
III-2	5	12	∞	2,03	77,9	1,55
IV-2	6	12	∞	2,76	∞	2,03
0-4	2	8	8,71	0,64	1,29	0,96
I-4	3	12	18,5	1,24	9,06	0,70
II-4	4	16	38,1	1,85	21,1	1,24
III-4	5	20	72,9	2,49	35,3	1,97
IV-4	6	24	138	3,17	53,0	2,80

Annex C
Concealed beam hanger connection

